

PLAN

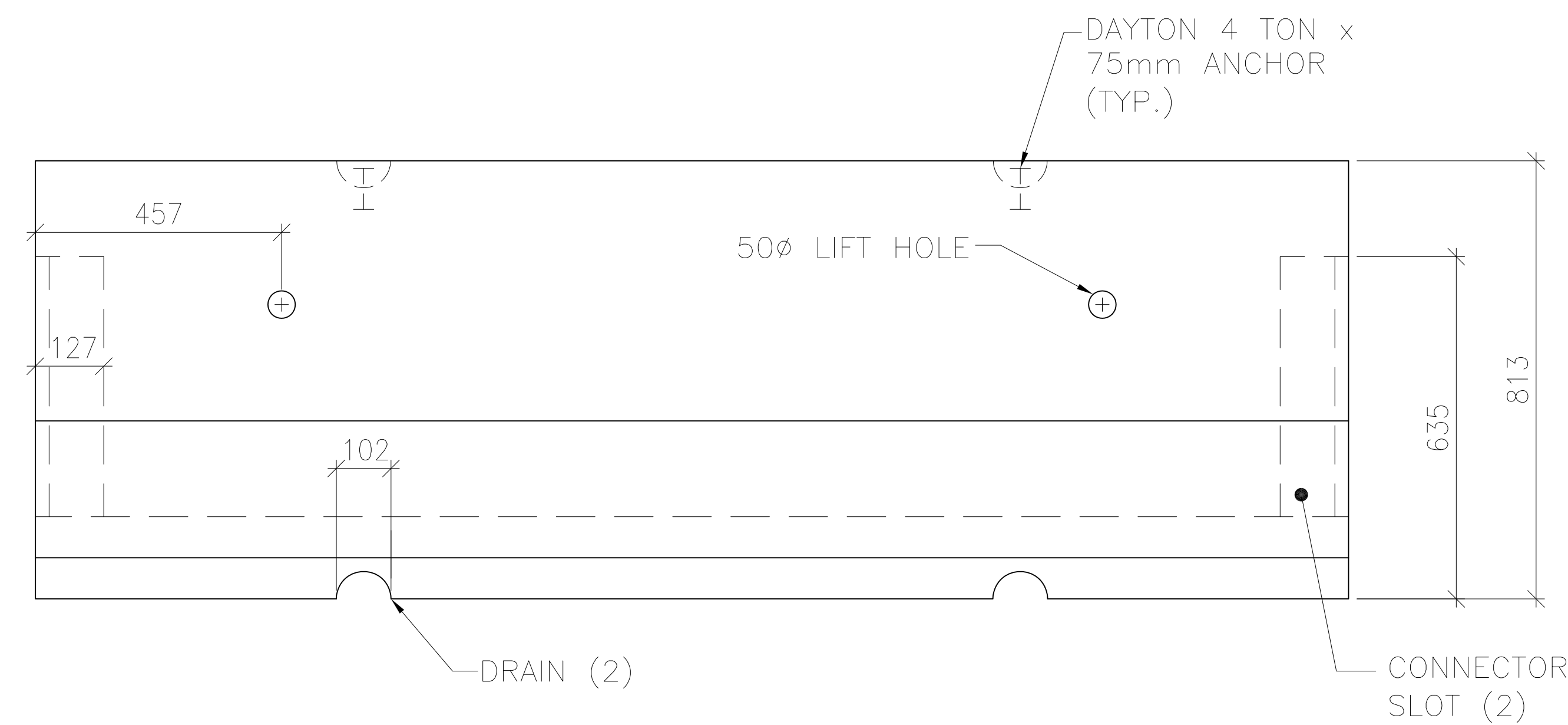

FRONT

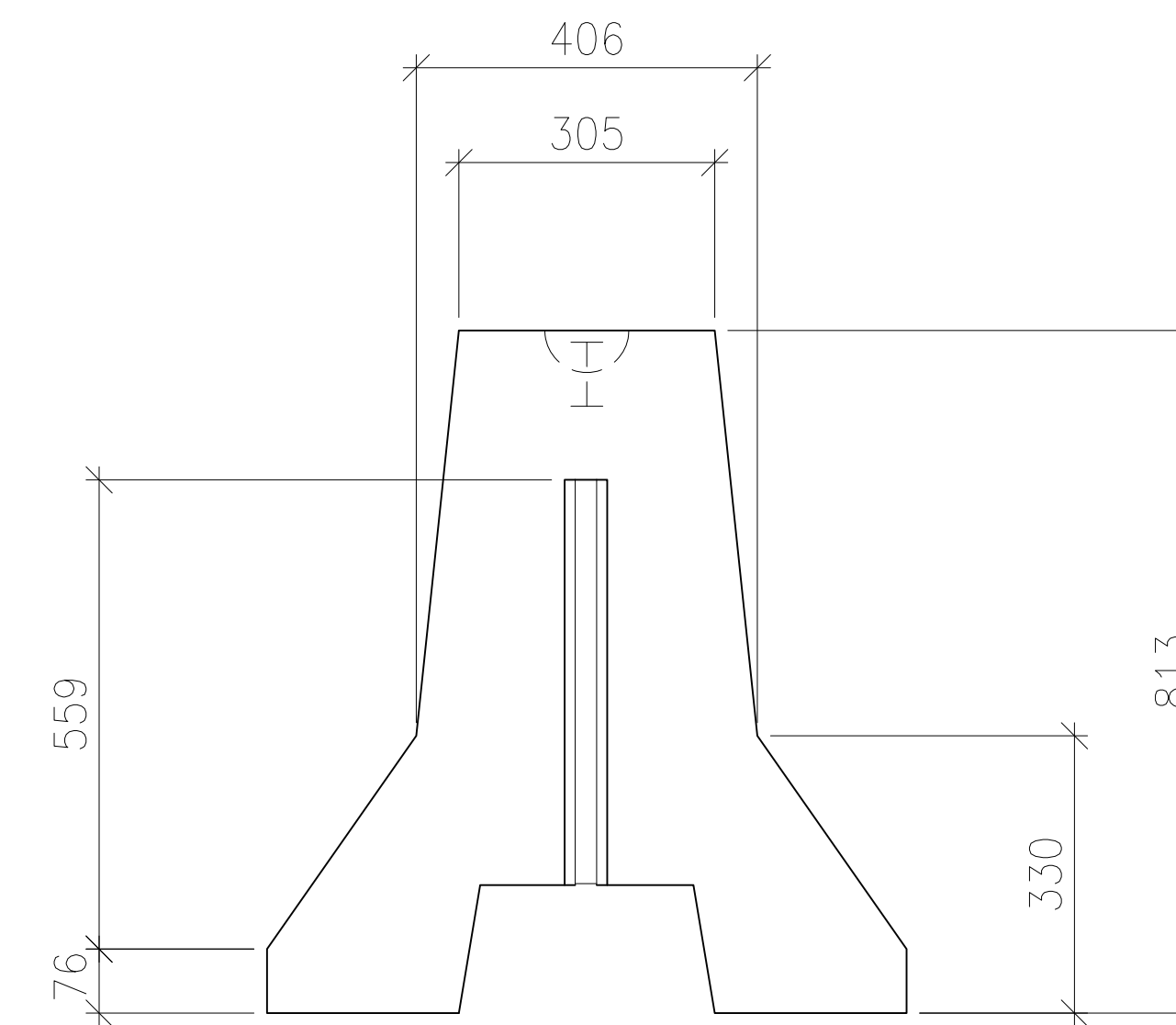

SIDE

NOTES

GENERAL

1. FOR HANDLING, STORAGE, TRANSPORTATION AND ERECTION PROCEDURES PLEASE REFER TO 'DAYTON/RICHMOND GUIDELINES FOR HANDLING CONCRETE PIPE AND UTILITY PRODUCTS'.
2. APPROXIMATE WEIGHT 2438mm = 1640kg.
3. TOLERANCE FOR STRUCTURAL ELEMENTS, MATERIALS & CONSTRUCTION CONFORM TO CAN/CSA A23.4 "PRECAST CONCRETE" CLAUSE 10.

REINFORCEMENT

1. ALL REINFORCING STEEL SHALL BE GRADE 400W AND CONFORM TO CAN/CSA G30.18 (LATEST EDITION).
2. ALL WELDED WIRE MESH SHALL HAVE A $F_y = 485$ MPA AND CONFORM ASTM A496 AND A497.
3. ALL REINFORCING SHALL BE DETAILED, FABRICATED, PLACED AND SUPPORTED IN ACCORDANCE WITH TO CAN/CSA A23.4 (LATEST EDITION).

CONCRETE

1. CONCRETE MIX DESIGNS SHALL CONFORM TO REQUIREMENTS SET FORTH IN CAN/CSA A23.1 EXPOSURE CLASS C1 WITH THE FOLLOWING CRITERIA:
 - CONCRETE STRENGTH = 20 MPa AT TIME OF STRIPPING
 - DESIGN CONCRETE STRENGTH OF 32 MPa AT 28 DAYS OR TIME OF SHIPPING
 - 5% TO 8% AIR ENTRAINMENT
 - MAXIMUM W/C RATIO = 0.45
 - GALLANT AGGREGATE SHALL BE USED WITH A NOMINAL AGGREGATE SIZE OF 13mm
2. CONCRETE CURING SHALL BE IN CONFORMANCE WITH CAN/CSA A23.1 (LATEST EDITION).
3. SHAW CONCRETE BATCH No. SHALL BE 406.

REV. NO.	REVISION	DATE

SHAW PRECAST CONCRETE PRODUCTS
 120 HURONTARIO ST. #2
 MISSISSAUGA, ONT. L4X 1L7
 CANADA
 PHONE: 1-800-885-2201
 FAX: 1-800-885-2215
 WWW.SHAWPRECAST.COM
 SHAW@SHAWPRECAST.COM

SPBARRIER6

DRAWING No. **STD-JB305TOPG2**

PROJECT TITLE
STANDARD PRODUCTS

PRODUCT CODE:
SPBARRIER6

DRAWING TITLE
STANDARD BARRIER
305mm TOP (12")
2438 x 762 BARRIER OR
1219 x 762 BARRIER

GEOMETRY

DATE MAY 2012	DESIGNED STAFF
DRAWN STAFF	CHECKED STAFF