

RECOMMENDED INSTALLATION PROCEDURES STORM AND SANITARY SEWER MANHOLES

Lifting Apparatus

Use approved lifting devices that will safely lift the weight of the unit with applicable OSHA requirements (Title 29 Part 1926) safety factor. When lifting manhole bases and risers, make sure the chain or cable lengths are long enough to prevent contact with the tongue and groove area, and are kept at appropriate lifting angles. Where safe lifting angles cannot be achieved, use appropriately rated spreader bars. The manhole lifting apparatus must meet or exceed safe working load capacity with respect to the lifting points. All lifting points should be used, and the product should be handled with equal "picking" force on all lifting points.

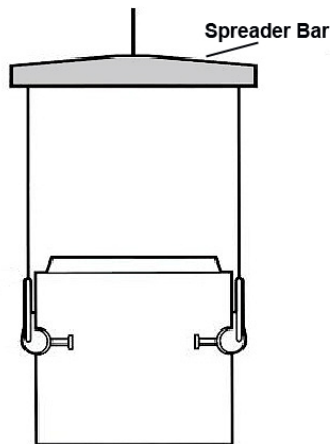

Recommended Manhole Bedding

Use a minimum of 6 inches of approved bedding material compacted to 90% Proctor in an area not less than the base area but preferably 6 inches beyond the outside radius of the manhole base. The area under incoming and outgoing pipes should be treated the same to prevent shearing of pipes and provide proper alignment for the watertight connector/pipe interface, if connectors are being utilized. Local ground conditions may require additional bedding thickness, based on the engineer's recommendations.

Handling Manhole Components

Manhole components should not be lifted using backhoes or front end loaders, unless they are of sufficient capacity to handle the product. Avoid transporting products across bumpy terrain at a speed that causes the product to bounce. Excessive travel bouncing of the product can cause damage. Also, avoid pushing or rolling a manhole product on the ground with on-site machinery.

Setting the Manhole Base and Risers

Set the manhole base on a graded bedding per job specifications making sure the connectors or pipe openings match design elevations. Level the top of the manhole base in both directions. Make sure each additional riser section is plumb as installed before installing the next riser, cone or cap.

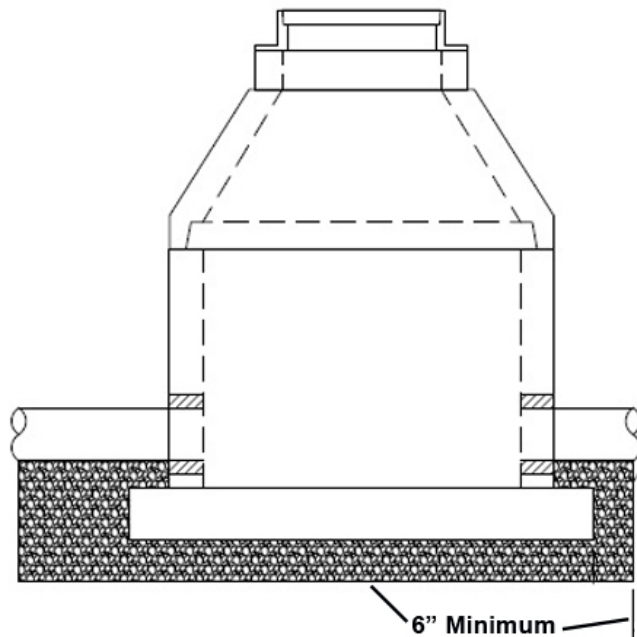

Use a minimum of 6" of approved bedding material compacted to 90% Proctor in an area that is 6" beyond the outside radius of the manhole base.

Pipe Connections

Should be based on manufacturer's recommendations. Check with the manufacturer if precast inverts are supplied.

Flexible Boot Connections – Clean the pipe surface and inside of boot. Insert the pipe flush with the inside of the manhole wall or as allowed by jurisdiction, keeping the pipe centered in the connector. Install all take up clamps(s) in groove(s), if provided, at the receiving end of connector. Tighten the clamp to the recommended torque, which will vary depending on size and manufacturer's specifications. Clamps should be tightened when the pipe is in straight alignment for proper seating of clamps. Any grouting that will inhibit the design/flexibility of the connector should be avoided.

Compression Type Connector – Cut a $\frac{3}{4}$ inch bevel on the end of the pipe to be inserted into manhole. Clean the pipe and connector surfaces and the inside area of the connector. Lubricate the surface of the connector and exterior area of the pipe being inserted with the approved lubricant. Center the beveled end of pipe into the connector. Keeping the pipe level, push the pipe into the connector until the pipe is flush with the inside of manhole wall or as required per local specifications.

Mortar Joint – Set the pipe into the opening to meet elevations. Using non-stick mortar, fill the voids around the pipe completely. Allow proper curing time before backfilling.



NPCA

Precast ... The Concrete Solution

Pipe Stubs

Any pipe stubs installed in the manhole must be restrained from movement to prevent blowout, resulting from groundwater or any testing.

Joint Installation

Ensure joints are free of debris.

Butyl Gasket – Use only manufacturer recommended sizes for specific diameters. Clean and inspect tongue and groove surfaces. Surfaces should be free from all dust and debris. On the tongue-up manhole, place butyl material next to the vertical surface of the tongue. Wrap the material completely around the unit overlapping ends. Knead the ends together to form a unified splice. Make sure all protective paper is removed. Lower the bell end of the next unit, making sure steps are aligned (if applicable) into the final position. If the bell is up, place butyl material next to the vertical surface of the groove and follow above procedure.

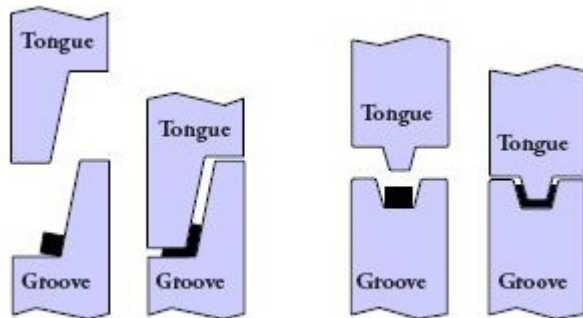

Confined O-Ring – Clean and inspect joint surfaces. Lubricate the joint surface liberally. Lubricate the O-Ring gasket thoroughly before placing it into the confined groove space provided. Run a smooth round object between the gasket and tongue around the entire circumference several times to equalize the gasket diameter. Lower the lubricated end of the next unit, making sure steps are aligned into the final position. Keep units plumb while setting to prevent the gasket from rolling out of the confined groove, which could result in breaking the bell.

Offset and Prelubricated Gaskets
– Install per the manufacturer's specifications.

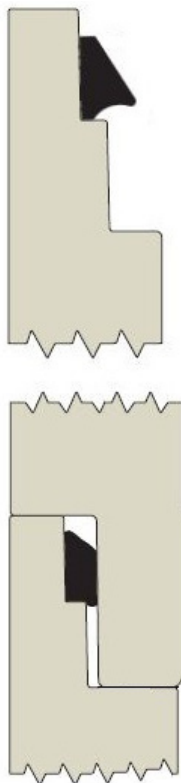

Precast Lift Hole Sealing (full penetration):

If required by an authority with jurisdiction, lifting holes should be sealed by inserting a rubber plug or other approved material into the hole (if supplied) and/or filling with non-shrink mortar from inside and outside. When using embed anchors, voids should be filled with non-shrink grout.

Backfill Procedure

Backfill around the manhole equally to prevent tipping. Compact the fill in the same way as the standard trench procedure. Backfill material should be clean and free of large rocks. The size of the vibration equipment should be suited for site conditions to avoid damage to the manhole.

Testing Procedures

vacuum tests should be performed before backfilling in accordance with ASTM C1244. There is no applicable standard for vacuum testing after backfilling, and this may require special consideration to vacuum pressure to account for soil and hydrostatic loads. Refer to the NPCA Manhole Vacuum Testing Brochure (precast.org/vacuum) for vacuum, hydrostatic and pressure testing where required.

Storage

If manhole products need to be stored on-site, make sure they are placed on level ground and not in mud or water to prevent damage. Dunnage can be used in these situations to avoid problems. Please consult with the manufacturer when storing manhole products for long periods.

Disclaimer

These procedures do not claim or imply that all safety-related issues, if any, associated with their use have been addressed. The manufacture of precast concrete products may involve the use of hazardous materials, operations and equipment. It is the user's responsibility to determine appropriate safety, health and environmental practices, and applicable regulatory requirements associated with the use of this manual and the manufacture of precast concrete products.

The use of these procedures does not guarantee the proper function or performance of any product manufactured in accordance with the requirements contained in the manual. Routine conformance to the requirements of this manual should result in products of an acceptable quality, according to current industry standards.